

Trackside Signal Range

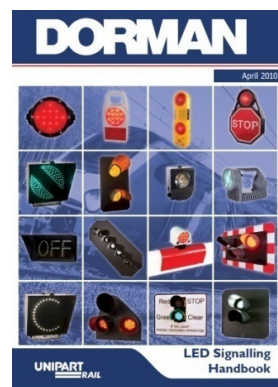

The Trackside Signal Range is just part of the wider portfolio of Dorman products which cover every part of the railway.



The LED Handbook contains full details of all the rail products. Contact us to receive your copy, or visit unipartrail.com/ledhandbook for the PDF version

Dorman's LED Signaling Range:

With over 25 years of experience in LED Rail Signaling, Dorman has a complete range of Network Rail approved LED signals that are backwards compatible with the existing systems on the UK infrastructure.

This comprehensive range covers nearly 500 approved items to date and Dorman has in excess of 60,000 signals now installed across the network. Where Dorman LED signals have been installed, failures and delays associated with the signal heads have been virtually eliminated.

Dorman, Design & Manufacturing Capabilities:

Dorman's engineering heritage goes back over 130 years. The innovation and design-led business philosophy revolves around listening closely to customers and ensuring product development is always focused on their requirements. Dorman is a leading light in rail with extensive product ranges available throughout the UK and in more than 30 countries across five continents.

Dorman has been at the forefront of LED technology since the 1980's. LED lighting offers unrivalled safety and economic benefits when compared to filament bulbs and the company's technological leadership has resulted in several industry 'firsts', including ConeLITE, the industry-standard warning lamp for road hazards, and the Dorman Position Light Signal, introduced in 2000 and the first LED signal for controlling train movements fully approved by Network Rail to Railway Group Standards.

Contact Details:

Dorman's range is distributed through Unipart Rail:

Unipart Rail
Gresty Road
Crewe
Cheshire
CW2 6EH

Tel: +44 (0)1270 847600
E-Mail: enquiries@unipartrail.com

www.dorman.co.uk
www.unipartrail.com

Banner Repeater



The Dorman Banner Repeaters are a fully Network Rail approved cost effective, direct replacement unit suitable for any installation with no requirement for on site design changes.

- Compliant with Network Rail Line Specification GK/RT0045
- Uses the same housing as Standard Alphanumeric Route Indicator and PRI
- Modular hinged assembly to enable ease of cleaning from a place of safety
- LED light sources designed to give a long and predictable service life
- Nominal supply voltage 110Vac/120Vdc
- Directly interchangeable with existing fibre optic units
- Reduced installation and maintenance costs
- Constant light output and colour throughout the life of the signal
- Unaffected by variations in supply voltage
- Compatible with existing SSI & RRI installations
- LED modules sealed to IP65

Two and three state versions available

UNIPART
RAIL

DORMAN

DORMAN

Banner Repeater

Product Details

Benefits

- No requirement for additional bespoke mounting brackets, tail cables or disconnection boxes - saving design, procurement and labour costs
- Dorman are the only manufacturer who have 120Vdc and 500mA versions both fully Network Rail approved



Maintenance and Signal Sighting

- The light sources are of a modular design enabling installation and replacement by a single operator via a simple lockable latch mechanism
- All signals are fitted with a fixed sighting device for increased sighting accuracy



Modules

- Each signal module is a self-contained IP65 sealed unit
- The modules can be secured using a standard padlock

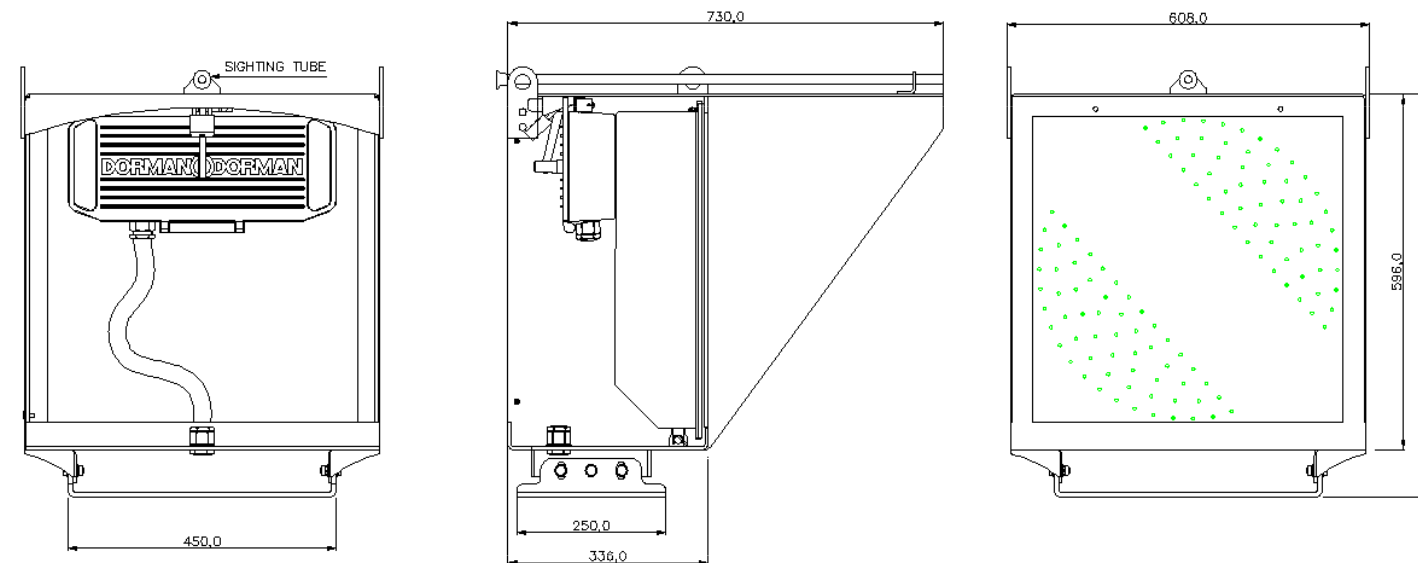

Safety

The light weight hinged signal module design enables all signal related maintenance to be performed from a position of safety.

Alignment

To enable alignment of the unit vertical adjustments are made using the hinged tilting mechanism and rotational adjustment is performed via the kidney slots in the signal base.



ON (White)
Be prepared to find the related Colour Light Signal at STOP



OFF (White)
Related Colour Light Signal is exhibiting a PROCEED aspect



OFF (Green)
Related Colour Light Signal is exhibiting a GREEN aspect

Network Rail Product Acceptance No:

PA05/02592 2 State
PA05/03054 3 State

PADS Nos:

2 State 500 mA Banner 0086/001320
2 State 300 mA Banner 0086/001346
3 State 300 mA Banner 0086/001339
Out of Use Mask 0050/000729