

Trainborne Range

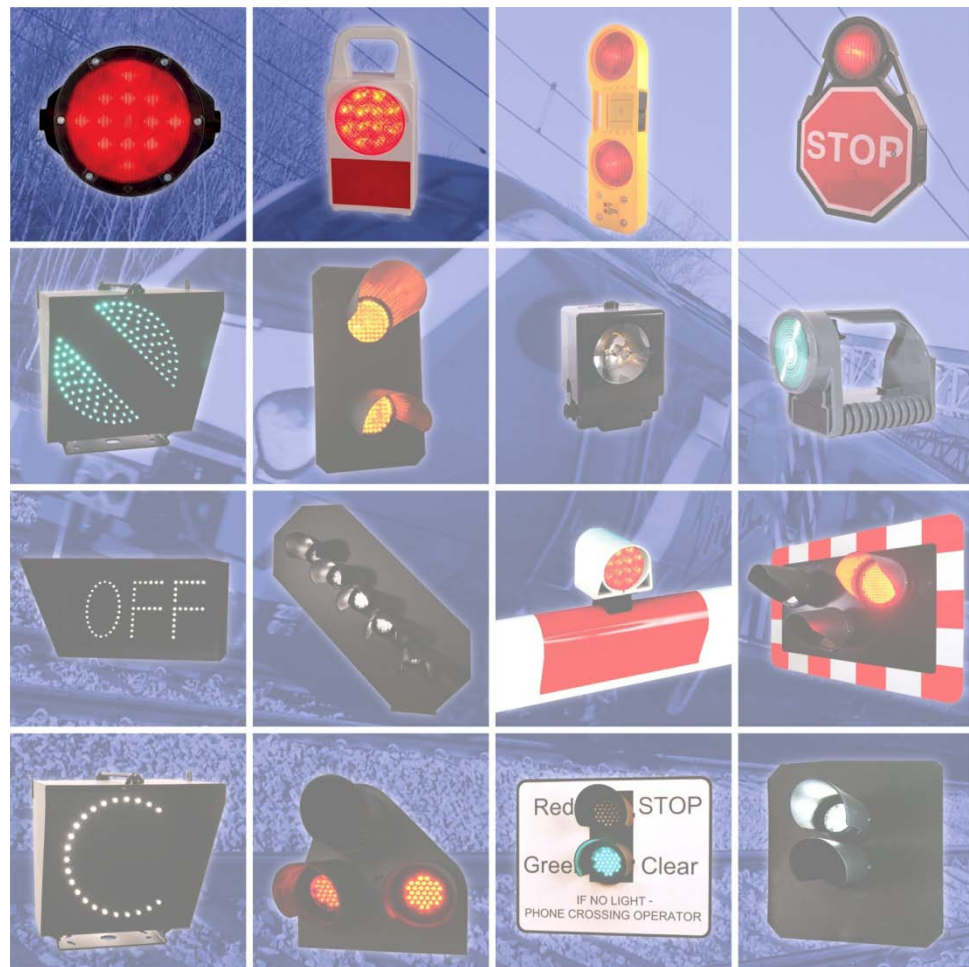

The Trainborne Range is just part of the wider portfolio of Dorman products which cover every part of the railway.

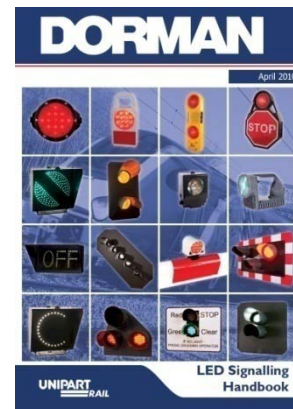

The LED Handbook contains full details of all the rail products. Contact us to receive your copy, or visit unipartrail.com/ledhandbook for the PDF version

Dorman's LED Signaling Range:

With over 25 years of experience in LED Rail Signaling, Dorman has a complete range of Network Rail approved LED signals that are backwards compatible with the existing systems on the UK infrastructure.

This comprehensive range covers nearly 500 approved items to date and Dorman has in excess of 60,000 signals now installed across the network. Where Dorman LED signals have been installed, failures and delays associated with the signal heads have been virtually eliminated.

Dorman, Design & Manufacturing Capabilities:

Dorman's engineering heritage goes back over 130 years. The innovation and design-led business philosophy revolves around listening closely to customers and ensuring product development is always focused on their requirements. Dorman is a leading light in rail with extensive product ranges available throughout the UK and in more than 30 countries across five continents.

Dorman has been at the forefront of LED technology since the 1980's. LED lighting offers unrivalled safety and economic benefits when compared to filament bulbs and the company's technological leadership has resulted in several industry 'firsts', including ConeLITE, the industry-standard warning lamp for road hazards, and the Dorman Position Light Signal, introduced in 2000 and the first LED signal which controlled train movement fully approved by Network Rail to Railway Group Standards.

Dorman product and specifications subject to change and/or modification without prior notice.

Contact Details:

Dorman's range is distributed through Unipart Rail:

Unipart Rail
Gresty Road
Crewe
Cheshire
CW2 6EH
UK

Tel: +44 (0)1270 847600
E-Mail: enquiries@unipartrail.com

www.dorman.co.uk
www.unipartrail.com

MK3 Portable Tail Lamp



The Dorman LED MK3 Portable Tail Lamp is compliant with UK Network Rail specifications and Rail Group Standards.

- High reliability LEDs
- High impact resistant polycarbonate lens and one piece body moulding
- Retro-reflective red panel
- Supplied with two 50Ahr Air Alkaline batteries
- Battery condition constantly monitored and displayed on both sides of the lamp
- Export versions available in either flashing or steady variants
- Robust rotary switch incorporating a solid state optical device with no moving contact parts
- Battery life is approximately 10,000 hours when continuously operated with two air alkaline batteries

MK3 Portable Tail Lamp

Product Details

Batteries

- The battery life is approximately 10,000 hours of continuous use when fitted with two 50Ahr Air Alkaline batteries.
- The battery condition is constantly monitored and the fitness for use is indicated on both sides of the lamp.

Compliant

Compliant with visibility group standard GM/RT 2483 : Issue 1.

Battery Compartment

The batteries are housed in a separate compartment which is secured with a thief proof bolt to preserve the lamps IP rating.



Product Features

- Robust rotary switch incorporating a solid state optical switch with no moving contact parts at the rear of the lamp.
- High reliability LEDs.
- Retro-reflective red panel.

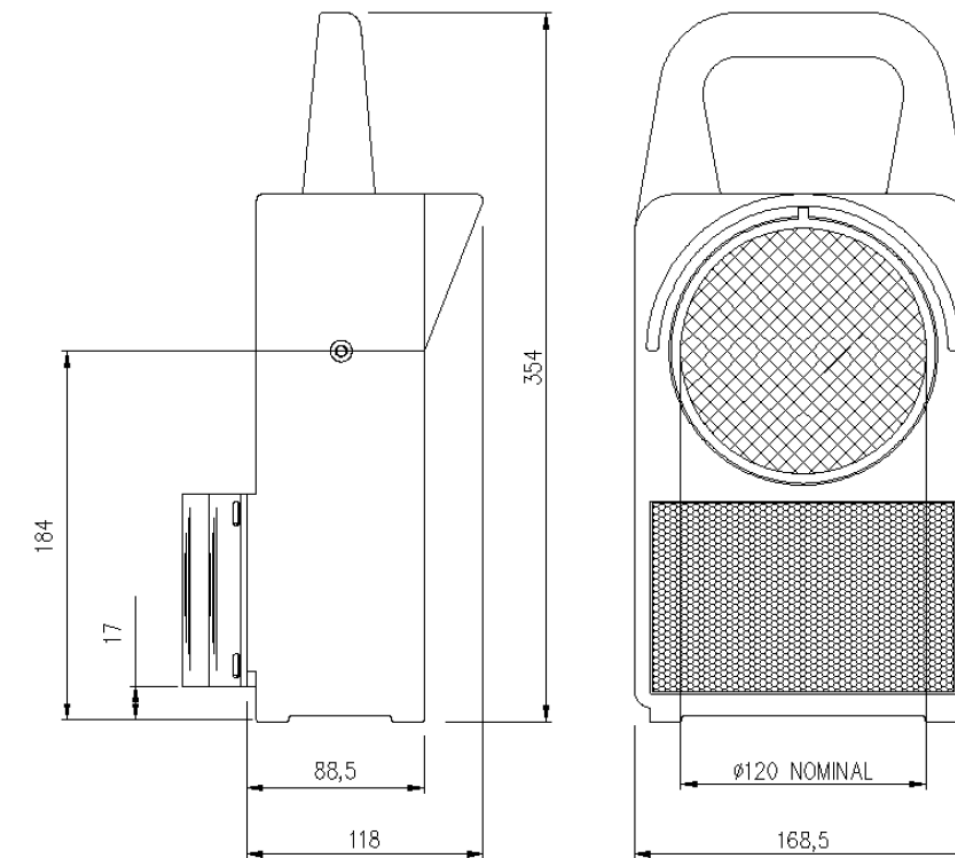

MK3 Portable Tail Lamp and Spares UK Variant

MK3 Portable Flashing Tail Lamp	PADS No: 0055/050319
50Ahr Air Alkaline Battery	0054/128366
Bracket and Fasteners	0055/039690

MK3 Portable Tail Lamp Export Variants

Portable Tail Lamp Flashing (with Solar Switch)	Dorman Pt No: ETMFS3/R
Portable Tail Lamp Flashing (No Solar Switch)	ETMFN3/R
Portable Tail Lamp Steady Light	IRTLN3/R
50Ahr Air Alkaline Battery	B13.12170

Lamp Sealing

All electronic components are sealed to IP65.

Mounting

Integral bracket for mounting on a standard UK lamp iron.

Flash Rate

The flashing variants all flash at a rate of 120 flashes per minute.