



LED Barrier Boom Lamp

Benefits

- > PADS No 086/028738
Dorman Part No BBL2N/R
- > Outstanding reliability with low maintenance LED Technology
- > Virtually zero maintenance costs
- > Quick and easy to fit in the time it takes to replace a filament lamp
- > Vandal resistant body
- > High impact resistant polycarbonate lens in vandal proof assembly
- > Requires no additional hood or fittings
- > Capable of withstanding severe shocks
- > Fully compliant with line specification RT/E/S/10073
- > Uses high brightness LED's (Signal Red Class B illumination)
- > MTBF to catastrophic failure 250,000 hours (29 years) of normal use
- > Sealed for life to IP54
- > Operating Voltage 24Vdc
- > Maximum operating current 50mA

General Dimensions of the Barrier Boom Lamp

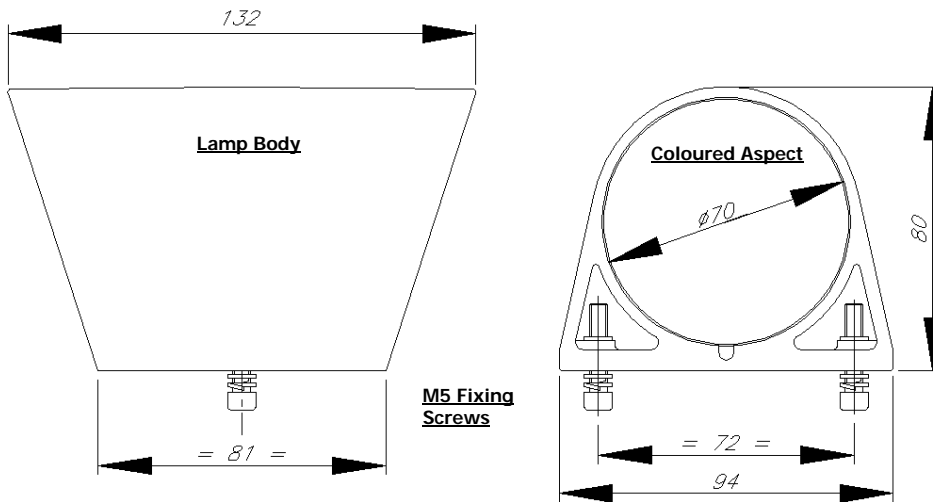

DORMAN
Wennington Road
Southport
Merseyside
UK PR9 7TN
T: +44 (0) 1704 518000
F: +44 (0) 1704 518001
E: sales@dorman.co.uk
www.dorman.co.uk



Certificate No. FM14371