



ConeLITE

Standard cone mounted, LED warning lamp for use at night

Benefits Include

- > Outstanding performance LED light source. Steady operation.
- > Polyethylene one piece body provides a high degree of toughness even at low temperature
- > Tough, high impact polycarbonate unidirectional lens is designed for maximum light output and incorporates a retro-reflective ring
- > Uses 6v zinc carbon battery. Air Alkaline batteries are available as an option to give exceptional battery life and almost constant 2 cd output for the entire operational life of the battery

- > Designed for quick and easy deployment.
- > Internally mounted on/off switch which is automatically activated when placed on to a cone and de-activated on removal from the cone. A photocell is fitted as standard with manual override switch
- > Efficient and reliable integrated circuit
- > Designed to meet all performance requirements of DFT and BS 3143 and complies with BS EN 12352:2000

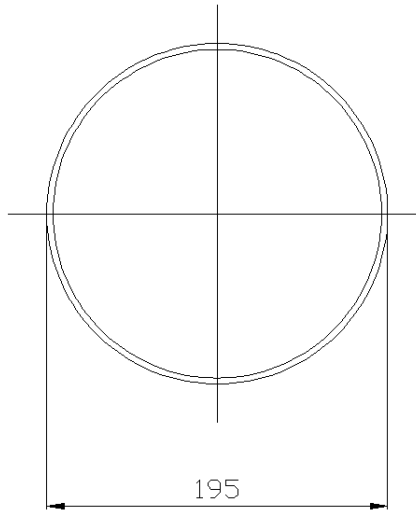
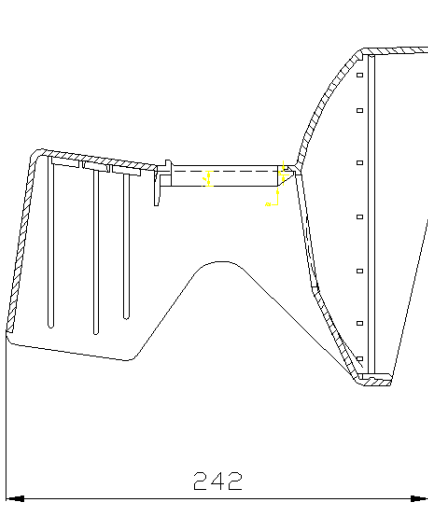

Weight (excluding battery)	455g
Standard zinc carbon battery	540g
DAAB25 air alkaline battery	640g
DAAB50 air alkaline battery	740g

Lamp supplied with steady light

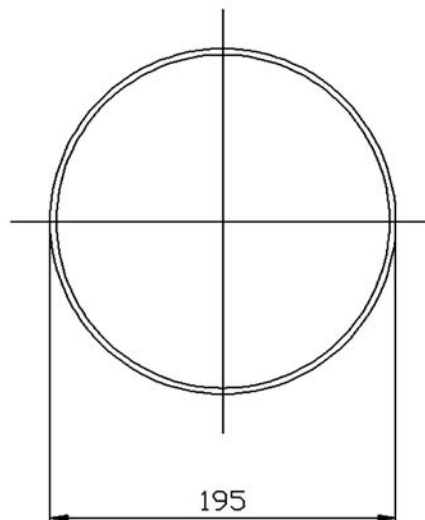
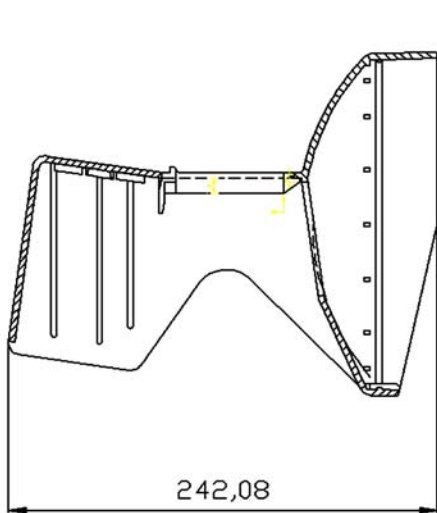

DORMAN
 Wennington Road
 Southport PR9 7TN
 T: +44 (0)1704 518000
 F: +44 (0)1704 518001
 E: sales@dorman.co.uk
 www.dorman.co.uk



Certificate No. FM14371