



### TrafiLITE LED

Popular hazard warning lamp with LED to give longer battery life

#### Benefits Include

- > Outstanding performance LED light source
  - > Can be supplied in flashing or steady mode
  - > Robust polypropylene body provides high strength
  - > High impact resistant tough bi-directional polycarbonate lens is designed to maximise light output and incorporates retro-reflective ring
  - > One or two batteries can be fitted. The orientation of the battery can be in any direction making replacement quick and easy. Anti-theft bolt discourages battery theft
- > Concealed, key operated tamper proof "on/off" switch
  - > Automatic standard solar photocell control improves battery life
  - > Scaffold bracket available as optional extra
  - > Cone bracket available as optional extra
  - > Complies with BS 3143 Part 2 & BS EN 13252:2000

# TrafiLITE LED

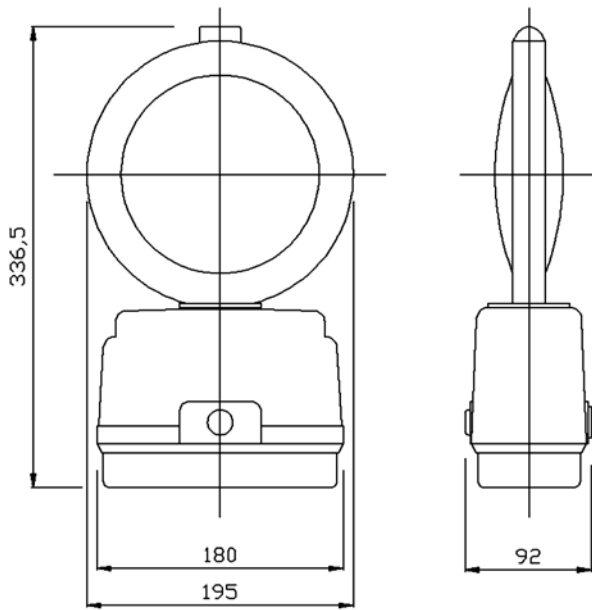

Weight (excluding batteries) 685g  
Standard zinc carbon battery 540g (each)  
DAAB25 air alkaline battery 640g (each)  
DAAB50 air alkaline battery 740g (each)

Can be supplied flashing or steady. Flash rate 60 flashes/min

PRODUCT DATA SHEET

DORMAN  
Wennington Road  
Southport PR9 7TN  
T: +44 (0)1704 518000  
F: +44 (0)1704 518001  
E: sales@dorman.co.uk  
www.dorman.co.uk



Certificate No. FM14371

**DORMAN**  
The Leading Light