



### LEDaLITE

Robust, economical hazard warning lamp for night operation

#### Benefits Include

- > 2 LEDs provide high intensity light source
- > Tough polypropylene body provides high strength
- > Tough, high impact resistant polycarbonate bi-directional lens designed to give maximum light output incorporates retro-reflective ring and hanging fixture
- > Key operated on/off switch is tamper proof. Can be switched from steady to flashing mode
- > Compact, single battery design requires minimum storage space
- > Air alkaline batteries may be fitted to greatly extend battery life. The orientation of the battery can be in any direction making replacement quick and easy
- > Optional easy fix cone mounting and scaffold fixing available.
- > Battery life – approximately 122 hours steady operation, approximately 444 hours flashing
- > Automatic photocell switching extends battery life
- > Complies with BS3142 Part 2 and BS EN 13252:2000

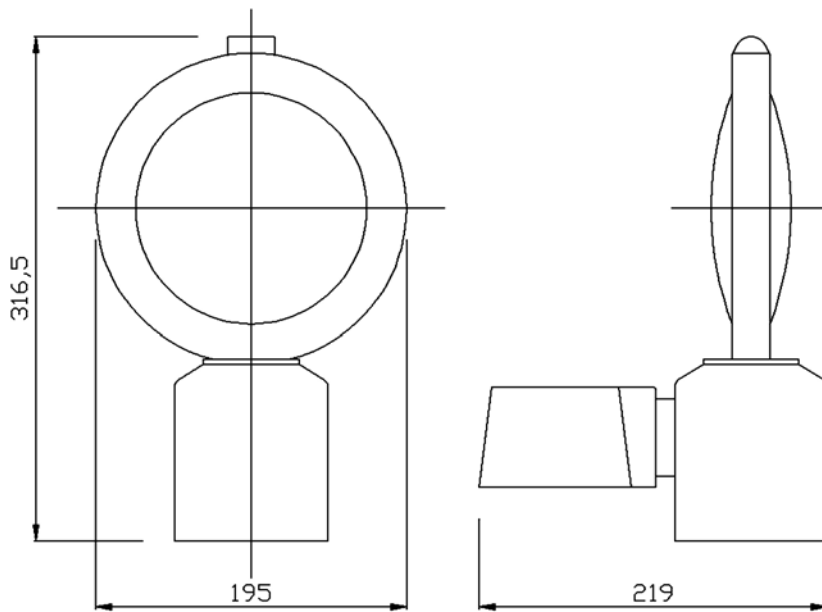

Weight (excluding battery) 642g  
 Standard zinc carbon battery 540g (each)  
 DAAB25 air alkaline battery 640g (each)  
 DAAB50 air alkaline battery 740g (each)

Flash rate – 60 flashes/min

DORMAN  
 Wennington Road  
 Southport PR9 7TN  
 T: +44 (0)1704 518000  
 F: +44 (0)1704 518001  
 E: sales@dorman.co.uk  
 www.dorman.co.uk



Certificate No. FM14371

**DORMAN**  
 The Leading Light