



Pro-B-LITE

High Intensity emergency hazard warning lamps, supplied with rechargeable batteries.

Benefits Include

- > Flashing high intensity uni-directional lamp using a single, super bright LED.
- > Can be supplied with or without backlight
- > High impact resistant tough polycarbonate uni-directional lens designed for maximum light output. Incorporates retro-reflective ring and metal carrying handle.
- > Robust polypropylene body provides high strength
- > Operates with rechargeable batteries supplied with lamp.
- > On/off switch facilitates simple, rapid operation and is concealed by a grommet
- > This unit is approved by the VCA for recharge within a vehicle
- > Optional wire stabiliser available
- > Operational battery life (full charge) in excess of 8 hours. Recharge time - 16 hours.
- > Charging base supplied separately. Part No D65.64002

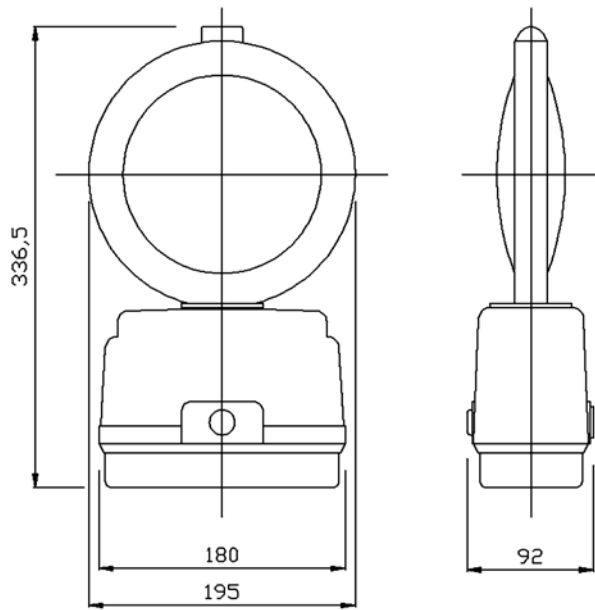

Weight (including batteries) 910g

Flash rate – 60 flashes/min

DORMAN
Wennington Road
Southport PR9 7TN
T: +44 (0)1704 518000
F: +44 (0)1704 518001
E: sales@dorman.co.uk
www.dorman.co.uk



Certificate No. FM14371

DORMAN
The Leading Light