



Sunflash

High intensity xenon hazard warning lamp can be used in bright conditions or fog

Benefits Include

- > Xenon discharge tube light source with a peak intensity of over 200,000 candelas. Available with either 60 flashes per minute or 120 flashes per minute
- > Robust polypropylene body provides high strength
- > Standard version is supplied with amber uni-directional lens. Bi-directional lenses can be supplied in amber, lemon, red or blue
- > Tough, high impact resistant polycarbonate lens designed for maximum light output, incorporates retro-reflective ring and metal carrying handle
- > Operates with 2 batteries
- > The orientation of the batteries can be in any direction making replacement quick and easy
- > Anti-theft bolt discourages battery theft
- > Back fixing bracket with thief proof bolt available as optional extra
- > Metal carrying handle fitted as standard
- > Cone bracket available as optional extra

Sunflash

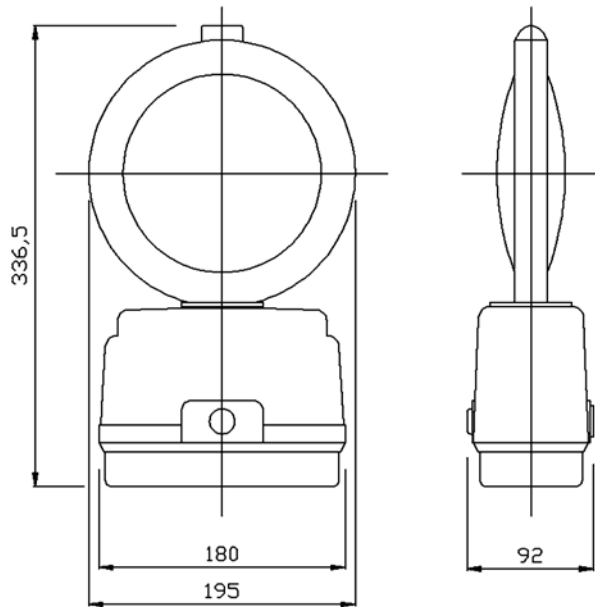

Weight (excluding batteries)	685g
Standard zinc carbon battery	540g (each)
DAAB25 air alkaline battery	640g (each)
DAAB50 air alkaline battery	740g (each)

Available with either 60 flashes/min or 120 flashes/min

PRODUCT DATA SHEET

DORMAN
Wennington Road
Southport PR9 7TN
T: +44 (0)1704 518000
F: +44 (0)1704 518001
E: sales@dorman.co.uk
www.dorman.co.uk



Certificate No. FM14371