



LED SynchroGUIDE

High intensity synchronised hazard warning lamp

Benefits Include

- > **Outstanding performance super bright LED with low intensity back light**
- > **Robust polypropylene body provides high strength**
- > **Over 100 lamps may be placed in line to give the impression of a single light source travelling along the lamps. Can be deployed in any order as there is no master or slave**
- > **High impact resistant tough polycarbonate uni-directional lens designed for maximum light output. Incorporates retro-reflective ring and metal carrying handle**
- > **On/off switch facilitates simple, rapid operation and is concealed by a grommet**
- > **Air alkaline batteries may be used for significantly extra life. Orientation of the batteries is not critical making replacement quick and easy.**
- > **Battery life with Air alkaline battery:
25amp hour, 525-850 hours
50amp hour 1050-1500 hours**
- > **Cone fixing bracket supplied as standard**
- > **Meets DFT specification for use on motorway and trunk roads. See Chapter 8.**

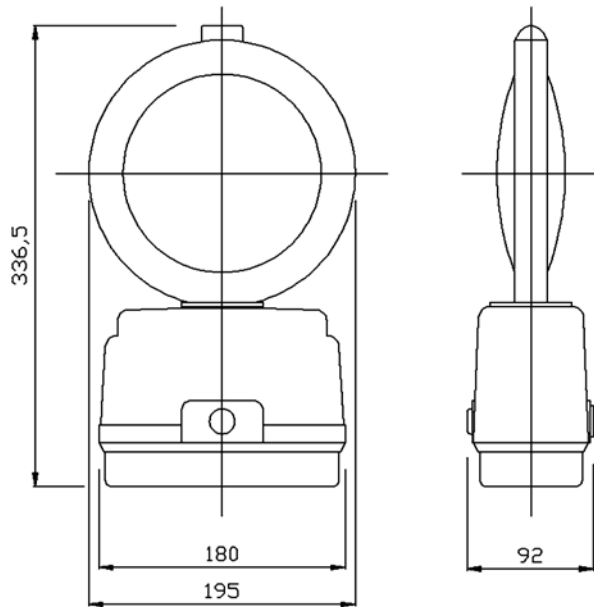

Weight (excluding batteries)	685g
Standard zinc carbon battery	540g (each)
DAAB25 air alkaline battery	640g (each)
DAAB50 air alkaline battery	740g (each)

Flash rate – 60 flashes/min

PRODUCT DATA SHEET

DORMAN
 Wennington Road
 Southport PR9 7TN
 T: +44 (0)1704 518000
 F: +44 (0)1704 518001
 E: sales@dorman.co.uk
 www.dorman.co.uk



Certificate No. FM14371