



TrafiLAMP E LED

General purpose hazard warning lamp for rough use.

Benefits Include

- > LED light source that can be purchased flashing or steady.
- > Heavy gauge steel construction, coated with stove epoxy resin paint is highly resistant to all forms of physical damage. Retro-reflective surface on body
- > High impact resistant tough polycarbonate lens designed for maximum light output, available in amber and red
- > Anti-theft bolt discourages battery theft
- > Trouble free, tamper proof on/off sliding switch
- > Automatic solar photocell fitted as standard
- > May be used free standing or secured by a strong vandal resistant bolt to a barrier, skip or scaffold bracket
- > Cone bracket and scaffold bracket available as extra
- > Complies with BS 3143 Part 2 & BS EN 12352:2000

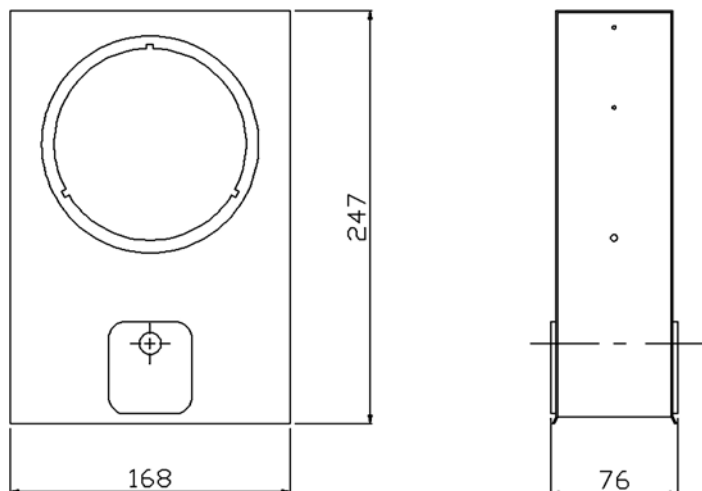

Weight (excluding batteries)	944g
Standard zinc carbon battery	540g (each)
DAAB25 air alkaline battery	640g (each)
DAAB50 air alkaline battery	740g (each)

Available flashing or steady. Flash rate – 60 flashes/min

DORMAN
 Wennington Road
 Southport PR9 7TN
 T: +44 (0)1704 518000
 F: +44 (0)1704 518001
 E: sales@dorman.co.uk
 www.dorman.co.uk



Certificate No. FM14371

DORMAN
 The Leading Light