



UniFLASH

360 degree lens, single battery high intensity xenon strobe lamp

Benefits Include

- > Outstanding daylight performance, xenon discharge tube gives a peak intensity greater than 22,000 cd and 60 flashes per minute
- > Polyethylene body provides a high degree of toughness even at low temperatures
- > High impact resistant tough polycarbonate 360° lens designed for maximum light output may be seen from any horizontal view. Available in blue, amber, red or green.
- > Compact single battery requires minimum storage space. Simple operation to change battery.
- > Positive twist action of lens to switch on / off. Can be purchased with or without photocell.
- > Ideal as emergency vehicle equipment where stowage space is limited
- > Cone fixing built in. Fitted with barrier fixing bolt and tie loop as standard.
- > Quick and easy deployment at emergency incidents

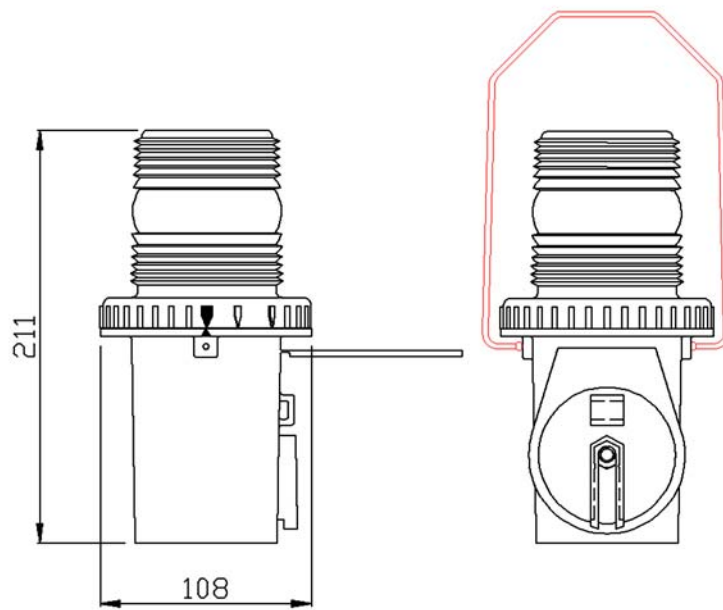

Weight (excluding battery)	813g
Standard zinc carbon battery	540g
DAAB25 air alkaline battery	640g
DAAB50 air alkaline battery	740g

Flash rate – 60 flashes/min

DORMAN
 Wennington Road
 Southport PR9 7TN
 T: +44 (0)1704 518000
 F: +44 (0)1704 518001
 E: sales@dorman.co.uk
 www.dorman.co.uk



Certificate No. FM14371

DORMAN
 The Leading Light