



### Pro-B-LITE Synchro

High intensity emergency hazard warning synchronised lamps, supplied with rechargeable batteries.

#### Benefits Include

- > Flashing high intensity uni-directional lamp using a single, super bright LED
  - > Can be supplied with or without back light.
  - > High impact resistant tough polycarbonate uni-directional lens designed for maximum light output, incorporates retro-reflective ring and metal carrying handle
  - > Operates with rechargeable batteries supplied with lamp
  - > On/off switch facilitates simple, rapid operation and is concealed by a grommet
- > Up to 15 lamps may be placed in line to give the impression of a single light source travelling along the lamps. Can be deployed in any order as there is no master/slave.
  - > This unit is approved by the VCA for recharge within a vehicle
  - > Optional wire stabiliser available
  - > Operational battery life (full charge) in excess of 8 hours. Recharge time – 16 hours
  - > Charging base supplied separately. Part No D65.64002

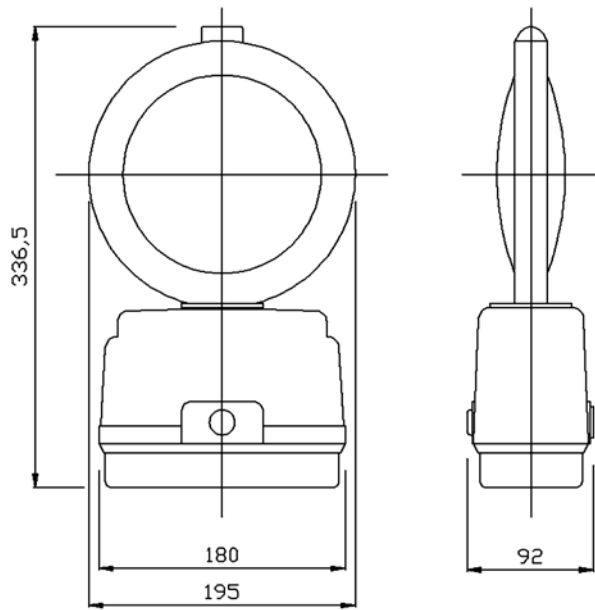

Weight (including batteries)

910g

DORMAN  
Rufford Road  
Crossens  
Southport PR9 8LA  
T: +44 (0)1704 220911  
F: +44 (0)1704 232221  
E: sales@dorman.co.uk  
www.dorman.co.uk



Certificate No. FM14371