



Trafi-B-LITE Synchro

High intensity synchronised hazard warning lamp

Benefits Include

- > Outstanding performance super bright LED. Can be supplied with or without backlight
- > Robust polypropylene case provides high strength
- > Over 100 lamps may be placed in line to give the impression of a single light source travelling along the lamps. Can be deployed in any order as there is no master or slave
- > Tough, high impact resistant polycarbonate uni-directional polycarbonate lens designed for maximum light output incorporates retro-reflective ring and metal carrying handle

- > On/off switch facilitates simple and rapid operation and is concealed by a grommet
- > Air alkaline batteries may be used for significantly extra life
- > Anti-theft bolt discourages battery theft
- > Cone fixing bracket available as optional extra with anti-theft bolt
- > Carrying tray supplied separately, Part No B09.08069

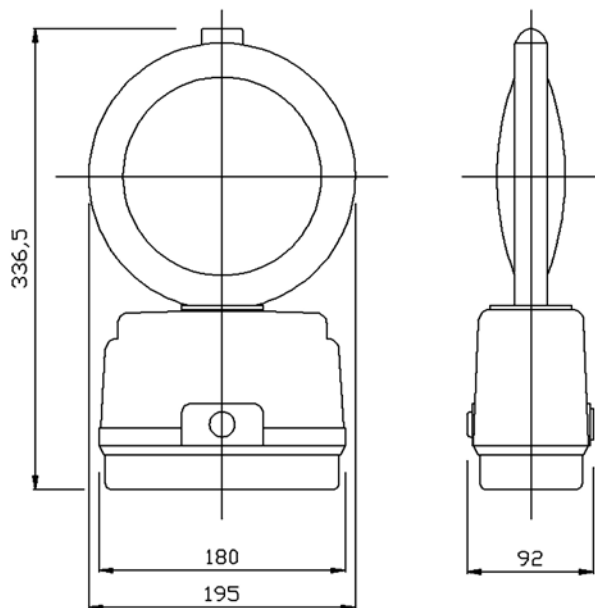

Weight (excluding batteries)	685g
Standard zinc carbon battery	540g (each)
DAAB25 air alkaline battery	640g (each)
DAAB50 air alkaline battery	740g (each)

DORMAN  
 Rufford Road  
 Crossens  
 Southport PR9 8LA  
 T: +44 (0)1704 220911  
 F: +44 (0)1704 232221  
 E: sales@dorman.co.uk  
 www.dorman.co.uk



Certificate No. FM14371

Jan08

**DORMAN**  
 The Leading Light