



Trafi-B-LITE

Benefits Include

- > **Flashing high intensity lamp using a single super bright LED**
- > **Robust polypropylene body provides high strength**
- > **High impact resistant tough polycarbonate uni-directional lens designed for maximum light output. Incorporates retro-reflective ring and metal carrying handle**
- > **Lens complies with BS EN 12352:2000 class L4F2 amber**
- > **On/off switch facilitates simple, rapid operation and is concealed by a grommet**
- > **Can be used with air alkaline batteries for significantly increased battery life**

High intensity LED hazard warning lamp

- > **The orientation of the batteries can be in any direction making replacement quick and easy**
- > **Back fixing bracket with thief proof bolt is available as optional extra**
- > **Cone fixing bracket available**

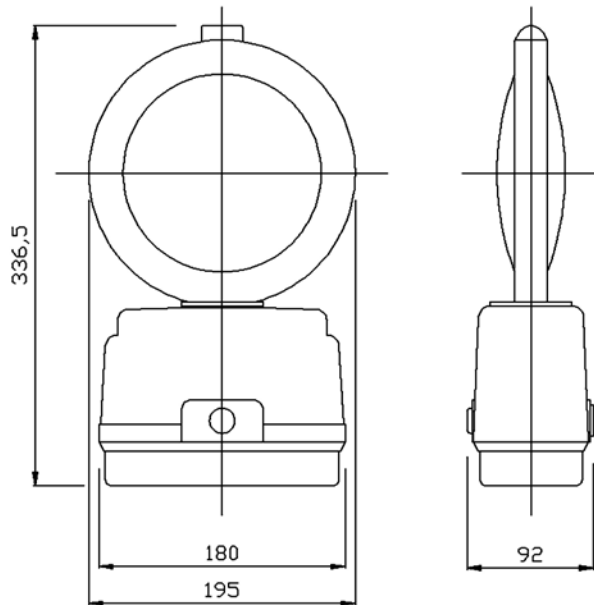

Weight (excluding batteries)	685g
Standard zinc carbon battery	540g (each)
DAAB25 air alkaline battery	640g (each)
DAAB50 air alkaline battery	740g (each)

Flash rate – 60 flashes/min

PRODUCT DATA SHEET

DORMAN
 Rufford Road
 Crossens
 Southport PR9 8LA
 T: +44 (0)1704 220911
 F: +44 (0)1704 232221
 E: sales@dorman.co.uk
 www.dorman.co.uk



Certificate No. FM14371