



### TrafiLITE LED

### Popular hazard warning lamp with LED to give longer battery life

#### Benefits Include

- > Outstanding performance LED light source
- > Can be supplied in flashing or steady mode
- > Robust polypropylene body provides high strength
- > High impact resistant tough bi-directional polycarbonate lens is designed to maximise light output and incorporates retro-reflective ring
- > One or two batteries can be fitted. The orientation of the battery can be in any direction making replacement quick and easy. Anti-theft bolt discourages battery theft
- > Can be used with air alkaline batteries

- > Concealed, key operated tamper proof "on/off" switch
- > Automatic standard solar photocell control improves battery life
- > Scaffold bracket available as optional extra
- > Cone bracket available as optional extra
- > Complies with BS 3143 Part 2 & BS EN 13252:2000

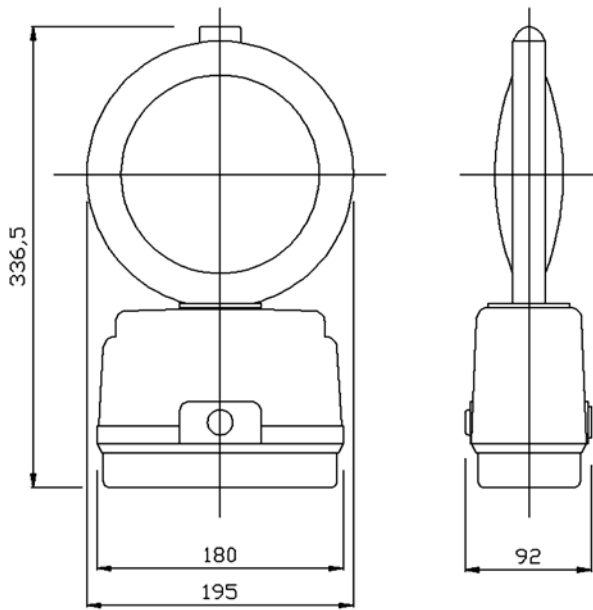

Weight (excluding batteries)	685g
Standard zinc carbon battery	540g (each)
DAAB25 air alkaline battery	640g (each)
DAAB50 air alkaline battery	740g (each)

Can be supplied flashing or steady. Flash rate 60 flashes/min

DORMAN  
 Rufford Road  
 Crossens  
 Southport PR9 8LA  
 T: +44 (0)1704 220911  
 F: +44 (0)1704 232221  
 E: sales@dorman.co.uk  
 www.dorman.co.uk



Certificate No. FM14371