



TrafiLITE

Benefits Include

- > Tungsten filament bulb supplied. Lamp operates in either flashing or steady mode
- > Robust polypropylene body provides high strength
- > High impact resistant tough polycarbonate lens designed for maximum light output and incorporates retro-reflective ring
- > Operates with one or two batteries. The orientation of the batteries can be in any direction making replacement quick and easy. Anti-theft bolt discourages battery theft
- > Concealed, key operated, tamper proof "on/off" switch

Popular hazard warning lamp

- > Optional automatic photocell "dusk to dawn" control improves battery life
- > Scaffold bracket available as optional extra
- > Cone bracket available as optional extra
- > Complies with BS3143 Part 2 & BSEN13252:2000

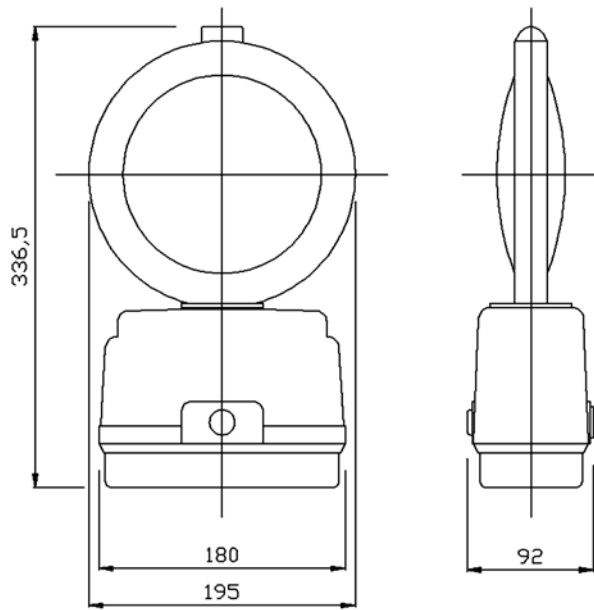

Weight (excluding batteries)	685g
Standard zinc carbon battery	540g (each)
DAAB25 air alkaline battery	640g (each)
DAAB50 air alkaline battery	740g (each)

Can be supplied flashing or steady. Flash rate – 60 flashes/min

DORMAN
 Rufford Road
 Crossens
 Southport PR9 8LA
 T: +44 (0)1704 220911
 F: +44 (0)1704 232221
 E: sales@dorman.co.uk
 www.dorman.co.uk



Certificate No. FM14371