



UniLAMP

Benefits Include

- > Flashing or steady lamp supplied with tungsten filament bulb.
- > Available as 60 or 120 flash/min and steady
- > Polyethylene case provides a high degree of toughness even at low temperature. Retro-reflective surface on body
- > High impact resistant tough polycarbonate 360 degree lens can be seen from any horizontal view. Amber lens fitted as standard, available also in red, blue, green and clear
- > Compact, single battery design requires minimum storage space

360 degree lens, single battery, with photocell for automatic switching

- > Easy battery change, simply push down and twist lens. Battery may be located in any position for quick and easy replacement
- > Positive twist action of lens to switch on/off
- > Automatic photocell for dusk to dawn operation saving battery life
- > Fitted with integral cone bracket, tie loop and barrier fixing bolt as standard.
- > Scaffold fixing bracket available as extra
- > Complies with BS 3143 Part 2 & BS EN 13252:2000

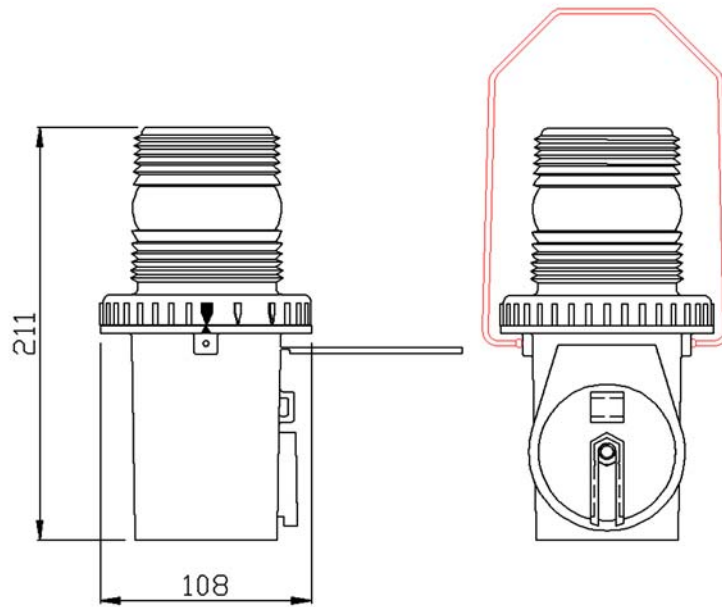

Weight (excluding battery) 813g
 Standard zinc carbon battery 540g

Available as 60 or 120 flashes/min or steady

DORMAN
 Rufford Road
 Crossens
 Southport PR9 8LA
 T: +44 (0)1704 220911
 F: +44 (0)1704 232221
 E: sales@dorman.co.uk
 www.dorman.co.uk



Certificate No. FM14371