



LED Handlamp

Benefits

- > PADS No 094/008050
- > Dorman Part No RLH2N/RYGW/P/OG
- > Network Rail Acceptance No PA05/02888
- > Direct replacement for the existing NRS Handlamp (formerly "Bardic")
- > Capable of withstanding severe shocks
- > LED's have a life in excess of 10 years
- > DORMAN LED Handlamps have a 250% energy saving over filament lamps giving a longer battery life of 20 hours (continuous use). Battery costs are reduced by over 60%.
- > Red, Yellow and Green aspects are true signal colours
- > "Battery OK" indication
- > Stable light output across battery life.
- > Integrated standard mounting bracket for use as emergency tail lamp / marker lamp
- > Made from high impact resistant polycarbonate
- > Handlamp 375g Battery 180g – over 50% less weight than existing Bardic handlamp
- > Replacement battery PADS No 094/008051 Dorman Part No B91.90018

GENERAL DIMENSIONS OF THE LED HANDLAMP

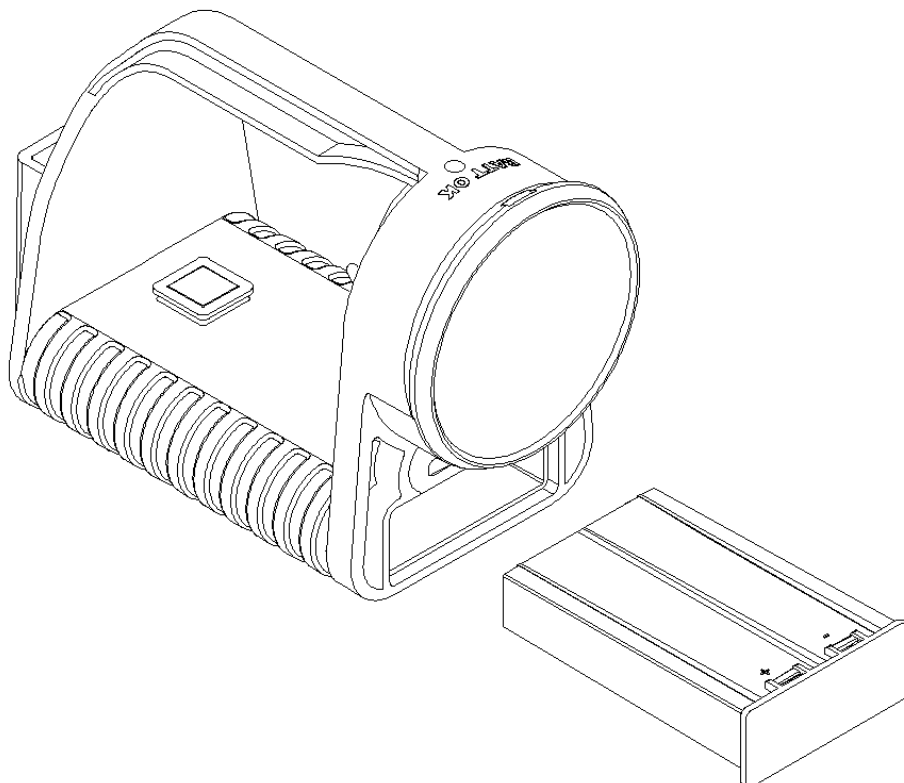
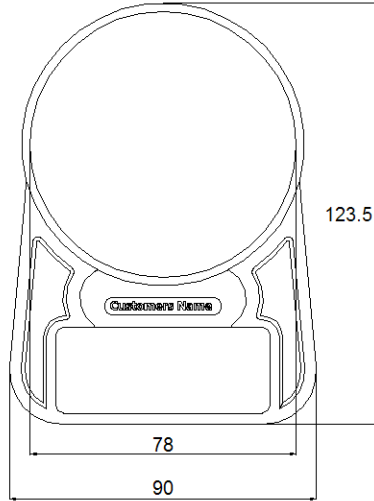
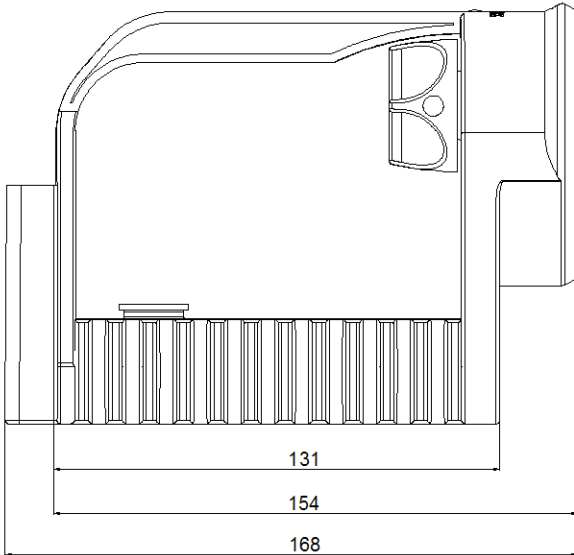

DORMAN
Rufford Road
Crossens
Southport PR9 8LA
T: +44 (0)1704 220911
F: +44 (0)1704 232221
E: sales@dorman.co.uk
www.dorman.co.uk



Certificate No. FM14371

www.dorman.co.uk

DORMAN
The Leading Light