

TES 1330A PHOTOSENSOR (8b) ATTACHED TO HOUSING

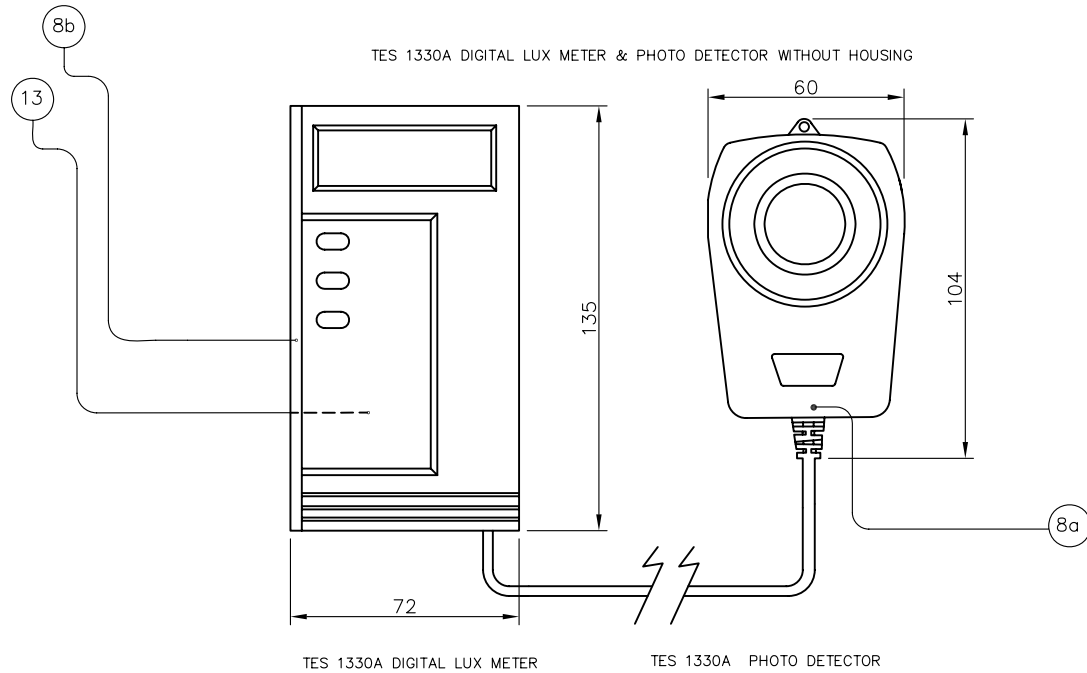

TES 1330A DIGITAL LUX METER

TES 1330A PHOTO DETECTOR

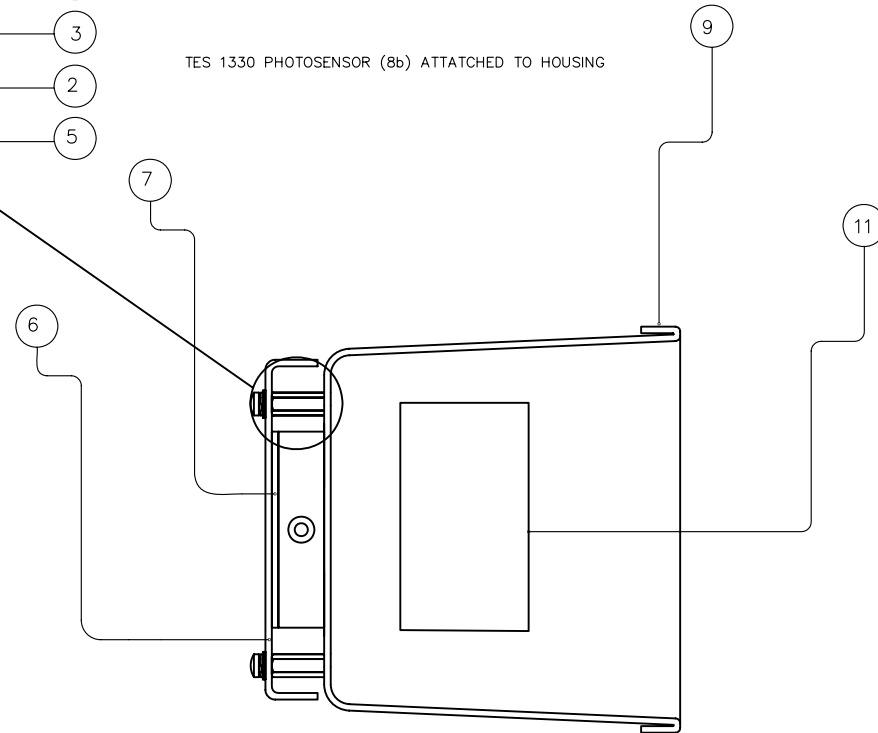
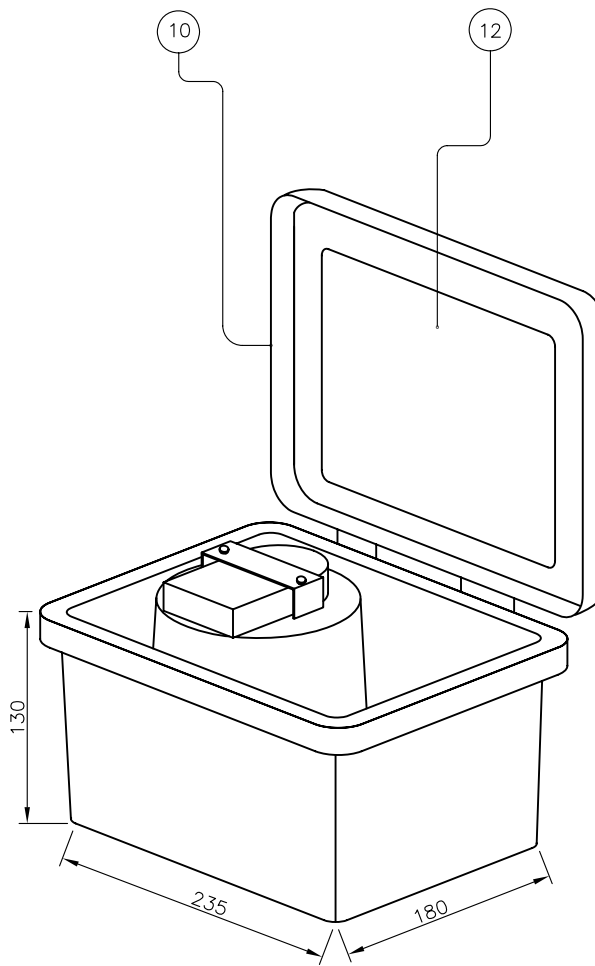

TYPICAL EQUIPMENT CARRYING CASE WITH LUXMETER, PHOTODETECTOR & HOUSING

ITEM	QTY	PART N°	DESCRIPTION
1	2	B18.17144	M4 X 16 BUTTON HEX SCREW
2	4	B18.17051	M4 SPRING WASHER
3	4	B18.17047	M4 PLAIN WASHER
4	2	B17.16135	M4 X 16 HEX SPCR M/F
5	2	B18.17050	M4 NUT
6	1	B21.20088	CLAMP PLATE
7	1	B09.08151	CLAMP PAD
8	1	B13.12267	TES1330 LUXMETER(b) & PHOTODETECTOR(a)
9	1	B21.20061	ALUMINIUM HOUSING SPINNING
10	1	B09.08218	EQUIPMENT CASE
11	1	C64.63333	LABEL LIGHT MEASURING TOOL (LMT 01)
12	1	C64.63233	LMT 01 OPERATING INSTRUCTIONS
13	1	C64.63391	METER BATTERY NOTE LABEL (FIT TO REAR)

NOTE: REMOVE BATTERY STAND AND DISGUARD BEFORE FITTING LABEL (C64.63391, ITEM 13) ON REAR OF METER. TEST TO WORKS TEST REQUIREMENT WTR 2107 BUILD ASSEMBLY TO WI 2104

1	29/09/04	IsW	DCC 2551
0	04/07/02	IW	ORIGINAL DCC No.
ISS	DATE	INI	ALTERATIONS

**DORMAN**

DORMAN TRAFFIC PRODUCTS LTD  
SOUTHPORT PR9 8LA ENGLAND

THIS DOCUMENT AND THE INFORMATION THEREIN IS CONFIDENTIAL AND MAY NOT BE USED OR DISCLOSED WITHOUT WRITTEN AUTHORIZATION

DRAWING / PART No.	ISSUE
LMT 01	1

TITLE LIGHT MEASURING TOOL 01 GA		THIRD ANGLE PROJ	
MATERIAL		TOLERANCES	
	X	+ / -	0,25
	X,0	+ / -	0,10
	X,00	+ / -	0,05
	X,000	+ / -	0,025
	ANGULAR	+ / -	0.25°

Document N° a98-510-1
DRAWN IAN WELDING
CHECK L. GREEN
DATE 19/05/2004
SCALE NTS
SHEET 1 OF 1 SHEETS

ALL DIMENSIONS IN mm UNLESS STATED OTHERWISE  
CUST REF NO. PADS No. 086/009922

**DO NOT SCALE**

ORIGINAL DRAWING FRAME : A3