

INTERNAL VIEW OF ENCLOSURE WITH LID REMOVED

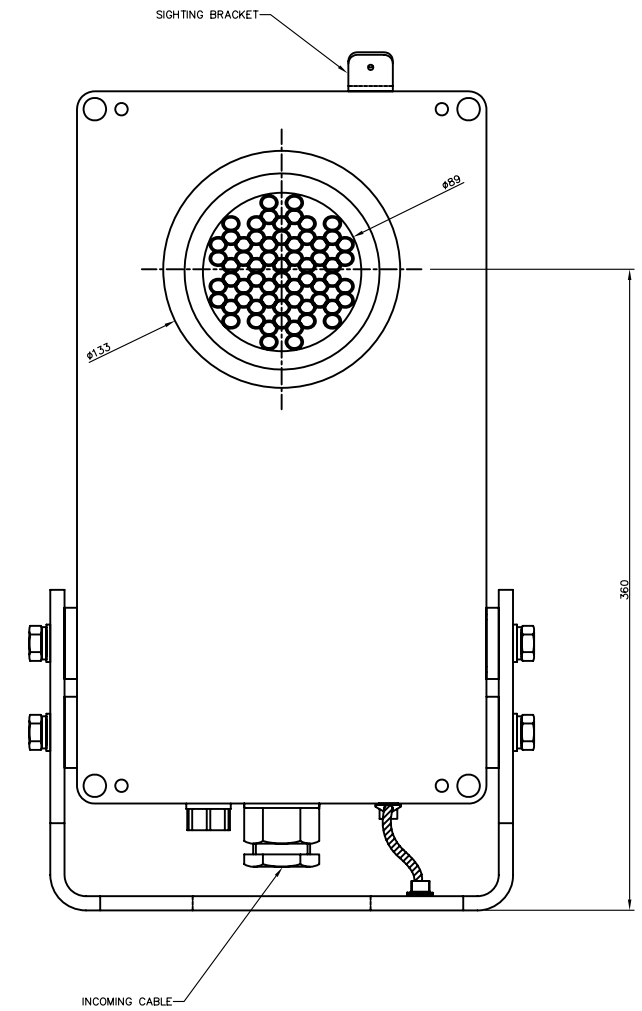

ITEM	QTY	DORMAN PART No.	DESCRIPTION
1	1	D86.85166	2 ASPECT ENCLOSURE & FRAME
2	1	MTM2/R/Y/1/P/G	MODULE 2 ASPECT RED/YELLOW (PADS No. 0086/009240)

TOTAL ASSEMBLED SIGNAL MASS ~ 10Kg.

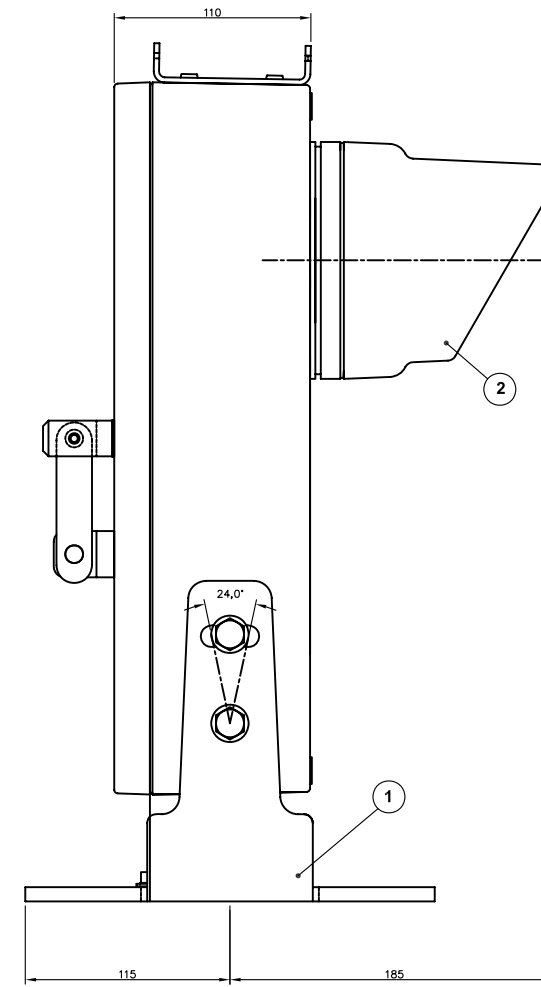
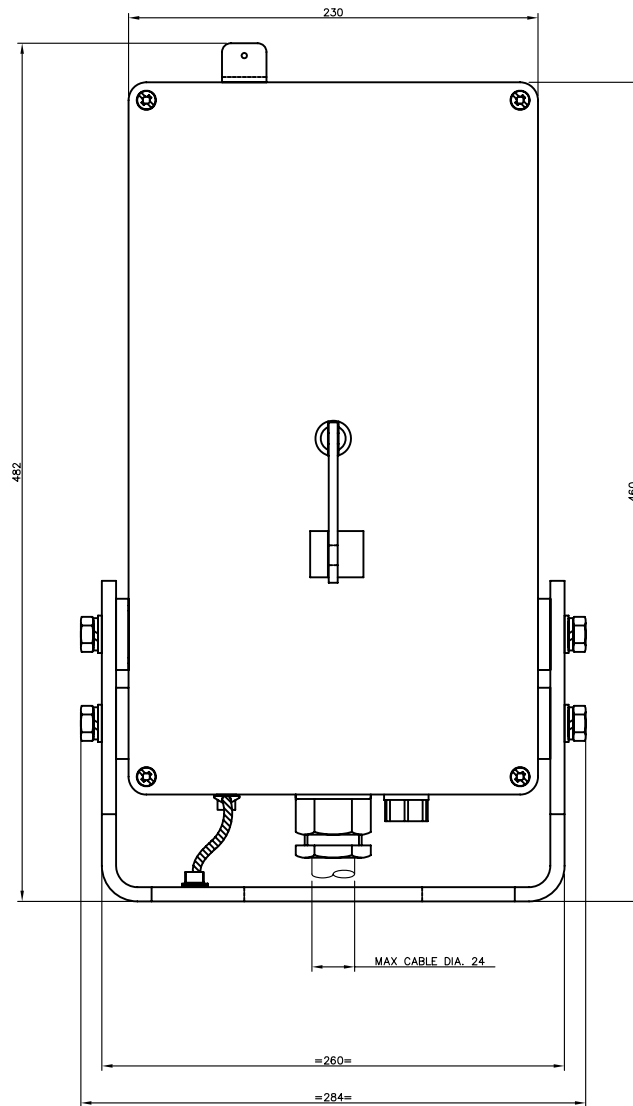
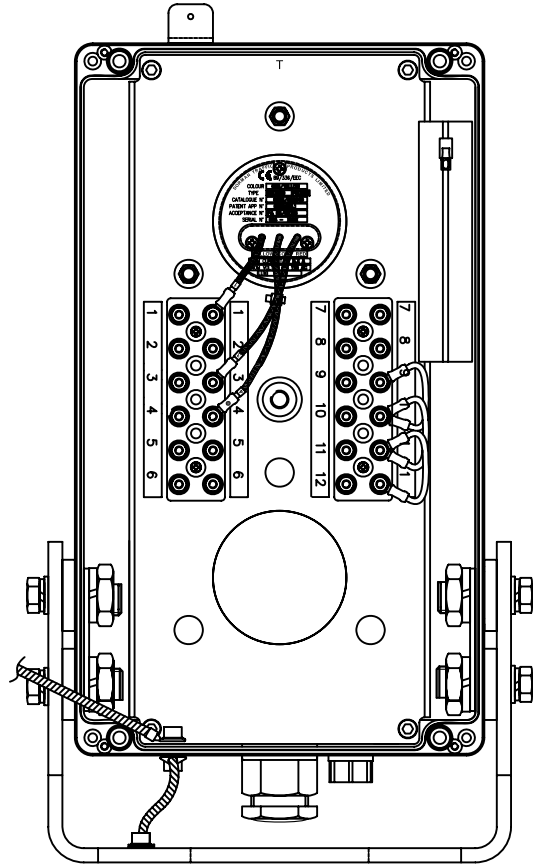
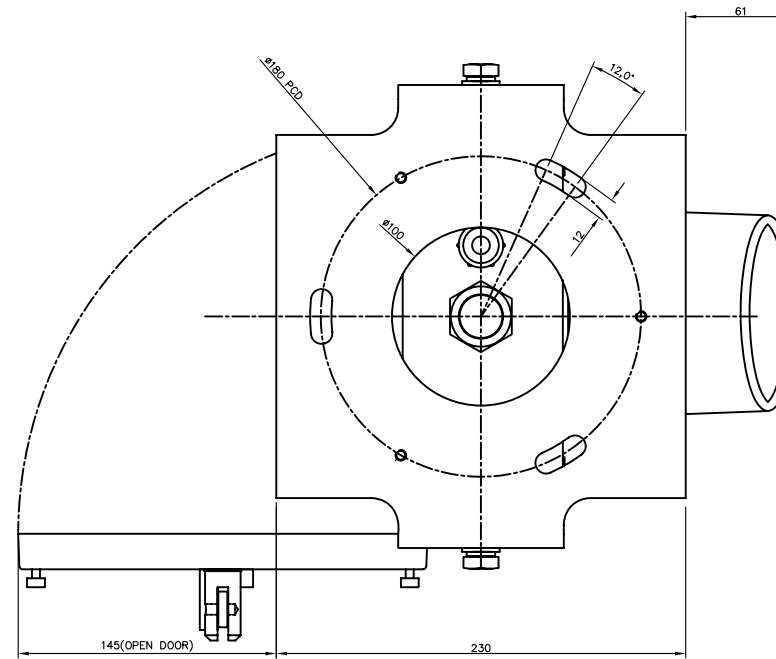

NOTES:-

- ALL ALUMINIUM COMPONENTS PAINTED ALL OVER WITH:
ONE COAT OF TRANSPED TWO PACK ETCH PRIMER 101
FOLLOWED BY :
ONE COAT OF BLACK MICACEOUS IRON OXIDE.
BR SPEC No. 70 ITEM 30. (FORWARD FACING PARTS)
ONE COAT OF LIGHT GREY MICACEOUS IRON OXIDE.
BR SPEC No. 70 ITEM 27A. (REAR FACING PARTS)
- WIRING DIAGRAM AND A DOCUMENT WALLET ATTACHED TO INTERNAL FACE OF THE BACK COVER.
- ALL FASTENERS ~ STAINLESS STEEL.
- RKB221 BRASS PADLOCK, PADS No.0086/029003 IS NOT SUPPLIED WITH THIS ASSEMBLY.

0	27/04/06	MD	DCC No.3158
ISS	DATE	INI	ALTERATIONS

DORMAN

DORMAN TRAFFIC PRODUCTS LTD SOUTHPORT PR9 8LA ENGLAND	
DRAWING No	PART No.
0086/009161	0

SPACE ENVELOPE/MECHANICAL INTERFACE DRAWING

TITLE 2 ASPECT (R/Y) MINIATURE TUNNEL SIGNAL		THIRD ANGLE PROJ Document N° 016-4712-1	
MATERIAL		TOLERANCES	
X	+ / -	0,25	
X,0	+ / -	0,10	
X,00	+ / -	0,05	
X,000	+ / -	0,025	
ANGULAR	+ / -	0,25°	
DRAWN M DURHAM		DATE 27/04/2006	
APPROVED L GREEN		SCALE NTS	
SHEET 1 OF 1 SHEETS		ISSUE	

ALL DIMENSIONS IN mm UNLESS OTHERWISE STATED

DORMAN REF No. MLTSH/2RY-/1P/G	CUSTOMER REF No.
-----------------------------------	------------------

DO NOT SCALE