

STENCIL INDICATOR S/OFF-----/1S SHOWN FOR REFERENCE

OUTSIDE FACES AND INTERNAL FRONT FACES PAINTED AS FOLLOWS
 ETCH PRIMER 2 PACK -BASE BR SPEC 81 ITEM 104A
 ACID BR SPEC 81 ITEM 104B
 TOP COAT - MICACEOUS IRON OXIDE MATT BLACK BR SPEC 70 ITEM 30

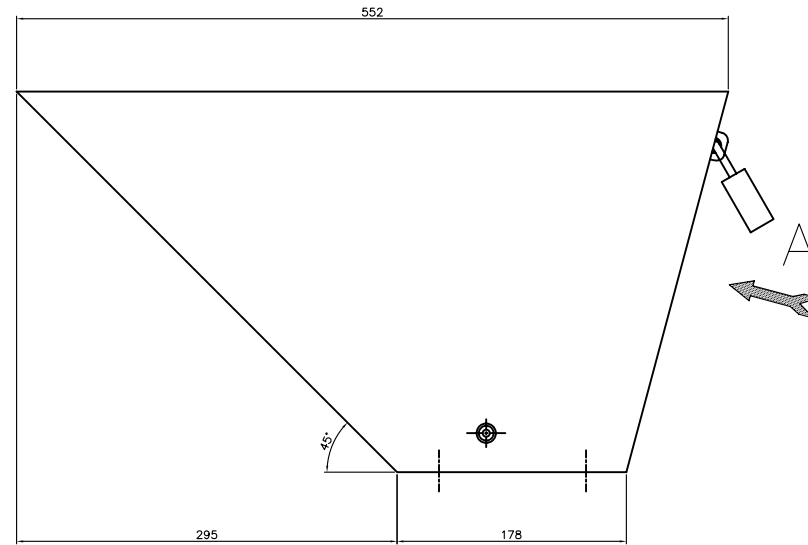

ITEM	QTY	PART N°	MATERIAL	DESCRIPTION
1	1	SEE CHART	ALUMINIUM FABRICATION/CASTING	SINGLE REAR ENCLOSURE
2	1	B20.19097	ALUMINIUM FABRICATION	OUTER COVER
3	1	B14.13105		EARTH BONDING STRAP
4	1	B18.17015	STAINLESS STEEL	M6 NUT
5	1	B18.17104		M6 x 10 SET SCREW
6	2	B18.17016		M6 SHAKE PROOF WASHER
7	1	PADS 0086/029003	BRASS	RKB221 PADLOCK

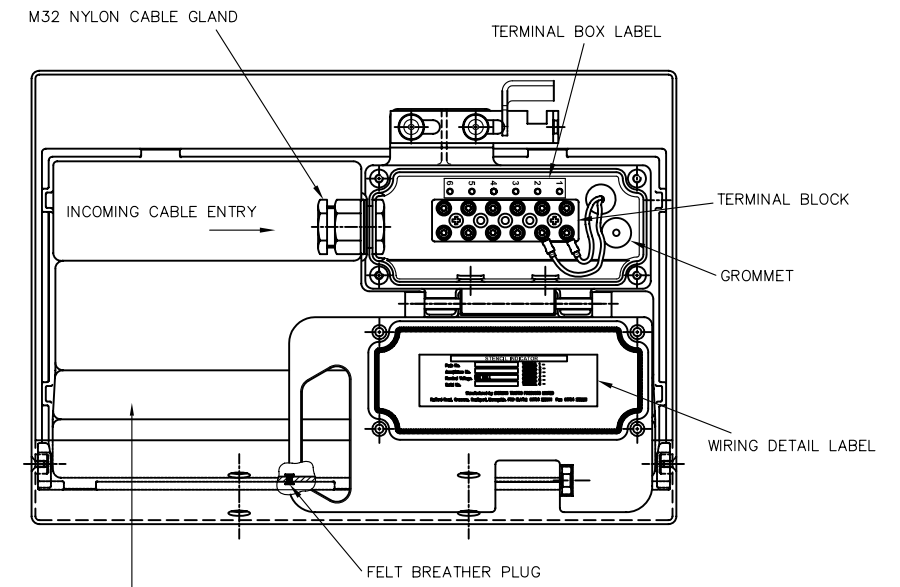

VIEW ON ARROW A
 WITH TERMINAL BOX COVER IN OPEN POSITION
 AND PADLOCK REMOVED

ALL INTERNAL REAR FACES PAINTED AS FOLLOWS
 ETCH PRIMER 2 PACK -BASE BR SPEC 81 ITEM 104A
 ACID BR SPEC 81 ITEM 104B
 TOP COAT - MICACEOUS IRON OXIDE LIGHT GREY BR SPEC 70 ITEM 27A

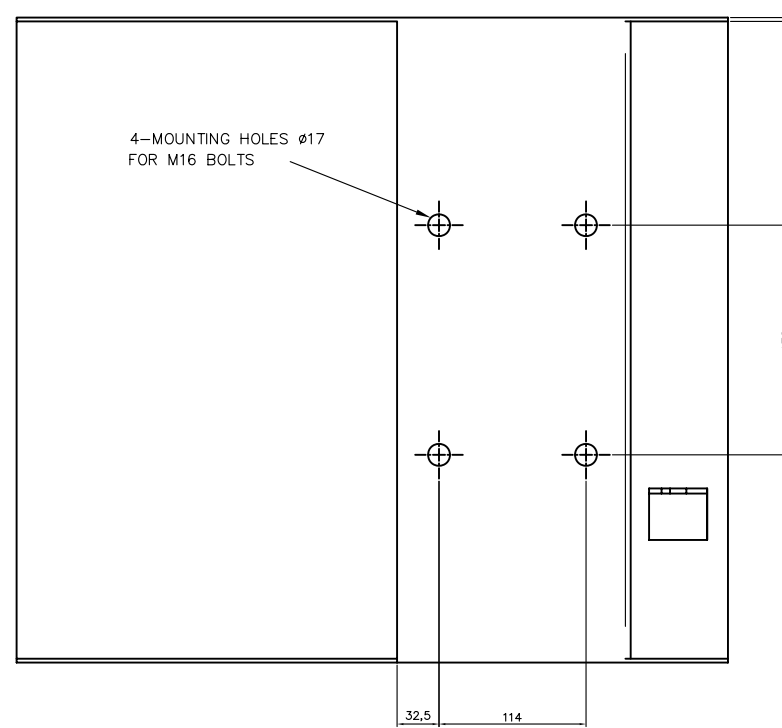
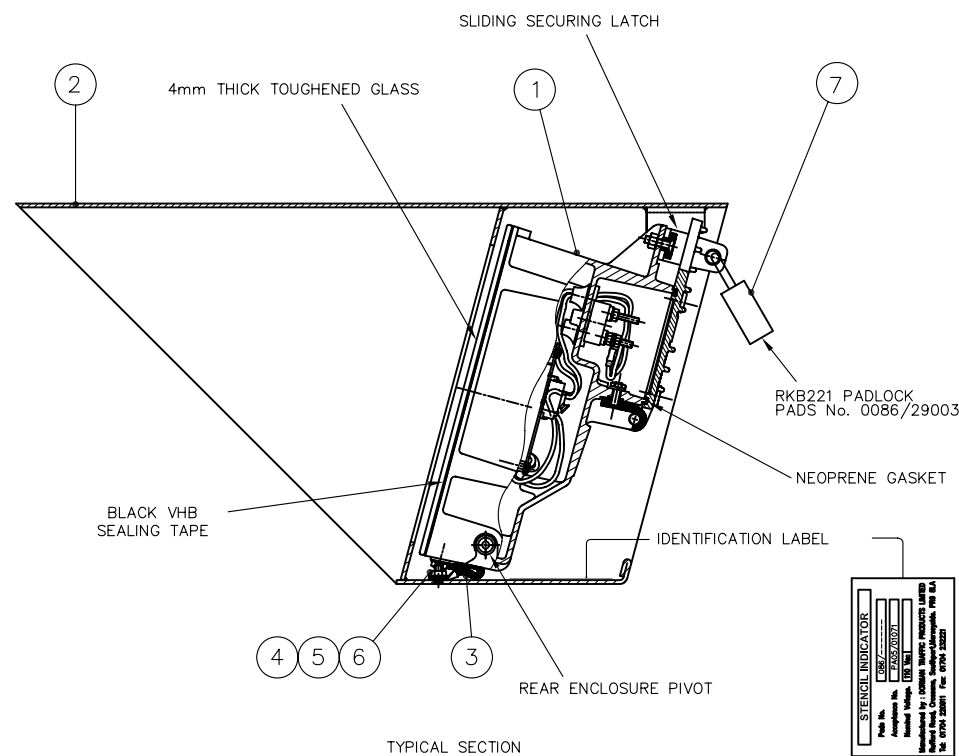

DETAIL OF OUTER COVER ITEM 2
 INNER ENCLOSURE NOT SHOWN FOR CLARITY

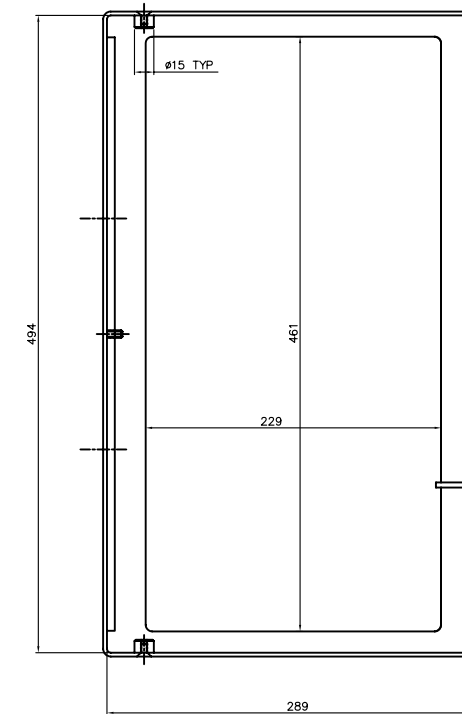

PADS No.	DORMAN PART No.	DESCRIPTION	REAR ENCLOSURE PART No.
086/021020	S/S-(SPECIAL)-/1S	SINGLE STENCIL INDICATOR,SPECIAL,110v,PROVING	CONTACT DORMAN SALES-RAIL
086/021022	S/RA-----/1S	SINGLE STENCIL INDICATOR,RA,110v,PROVING	D82.81002
086/021023	S/OFF-----/1S	SINGLE STENCIL INDICATOR,OFF,110v,PROVING	D82.81003
086/021024	S/CD-----/1S	SINGLE STENCIL INDICATOR,CD,110v,PROVING	D82.81006
086/021025	S/CD:RA-----/1S	SINGLE STENCIL INDICATOR,CD:RA,110v,PROVING	D82.81007

TOTAL WEIGHT OF UNIT = 14 Kg

ALL DIMENSIONS IN mm UNLESS OTHERWISE STATED

DORMAN REF No. CUSTOMER REF No.

NETWORK RAIL ACCEPTANCE No. PA05/01701

TITLE		THIRD ANGLE PROJ	
MINIATURE ALPHANUMERIC ROUTE INDICATOR INTERFACE DRAWING		Document N° 0100-4681-1	
MATERIAL	TOLERANCES	DRAWN	BT
	X	APPROVED	LG
	X,0	DATE	25/04/2006
	X,00	SCALE	1:1
	X,000	SHEET	1 OF 1 SHEETS
	ANGULAR		

0	25/04/06	BT	DCC No.3155
ISS	DATE	INI	ALTERATIONS

DORMAN

DORMAN TRAFFIC PRODUCTS LTD
 SOUTHPORT PR9 8LA ENGLAND

THIS DOCUMENT AND THE INFORMATION THEREIN IS CONFIDENTIAL AND MAY NOT BE USED OR DISCLOSED WITHOUT WRITTEN AUTHORIZATION
 DRAWING No PART No. ISSUE
 MINIATURE ALPHANUMERIC ROUTE INDICATOR INTERFACE DRG - PADS REF. 0

DO NOT SCALE

ORIGINAL DRAWING FRAME A1 DO NOT SCALE